

UBS

zNextGen@Berlin

4. Juli 2007



Agenda von heute

- ◆ UBS als Firma: Der “One Firm” approach
- ◆ How does IT Infrastructure (ITI) fit into UBS
- ◆ Mainframe Architecture & Engineering (some facts and figures)
- ◆ UBS als Arbeitsgeber
- ◆ Fragen & Antworten

Integrated Business Model

This is who we are...

Globally focused model

- ◆ Global focus:
 - Wealth Management
 - Asset Management
 - Investment Banking
- ◆ Business Banking has a focus on Switzerland only
- ◆ Targeting above GDP growth businesses
- ◆ Integrated model as key differentiator – "One Firm" approach

This is who we are not...

Global mega-bank

Niche firm

Global Presence

~557 offices globally

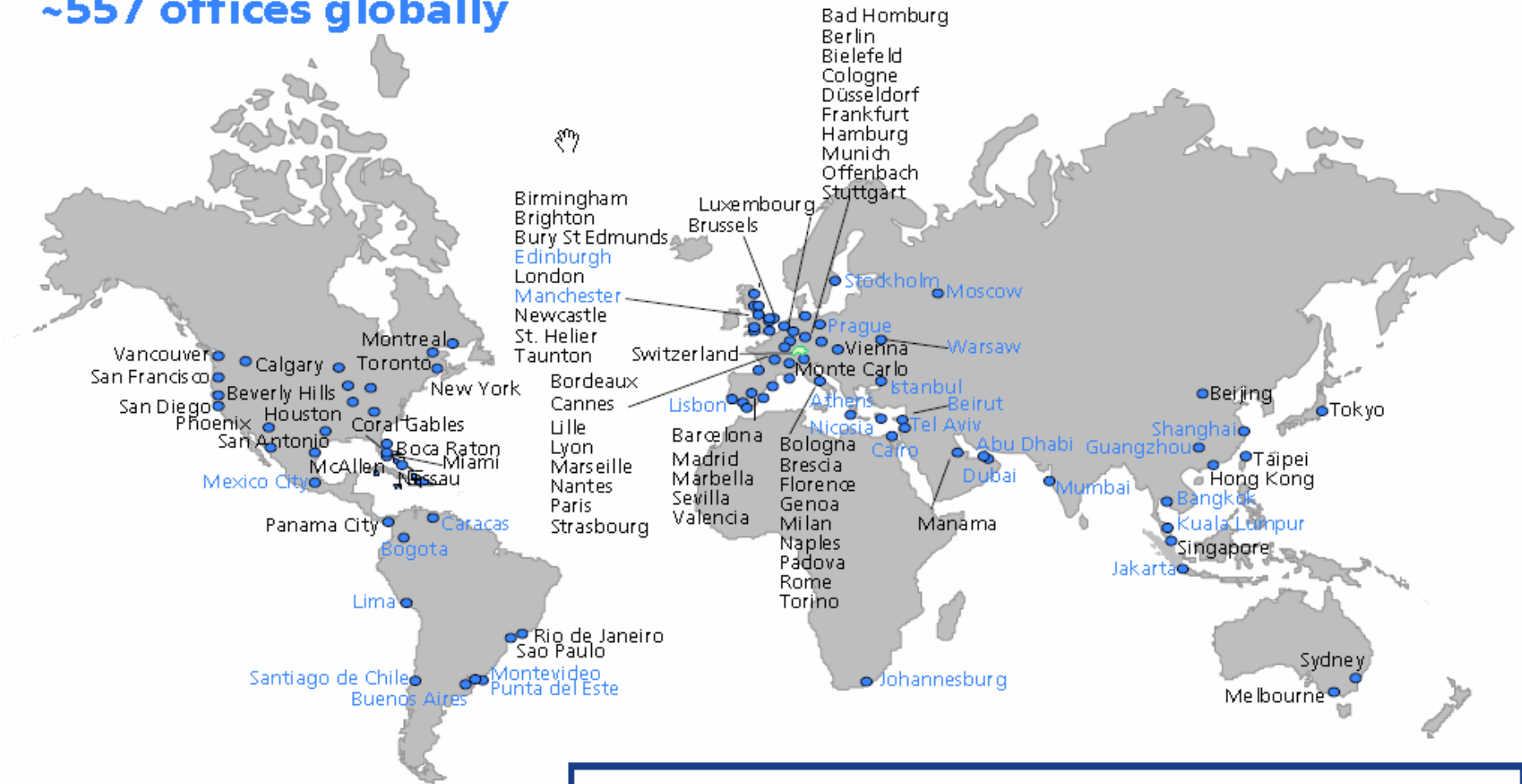

weltweit
~79'890
Angestellte

70 Wealth Management Offices worldwide
(additionally **111** locations in Switzerland)
30 UBS Representative Offices
346 Wealth Management US branch offices in the US

Roots

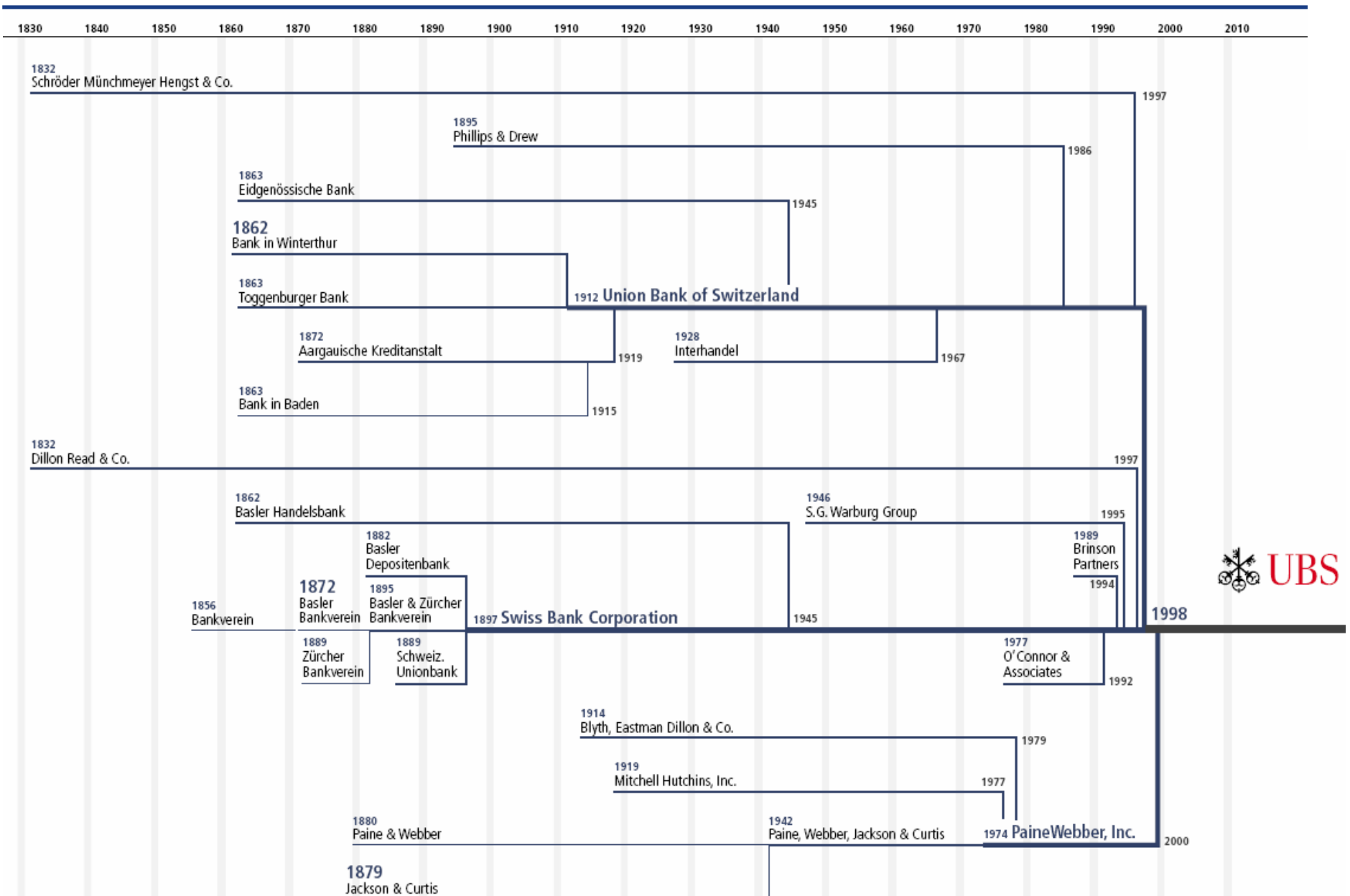

How does ITI fit into UBS

UBS Business Structure

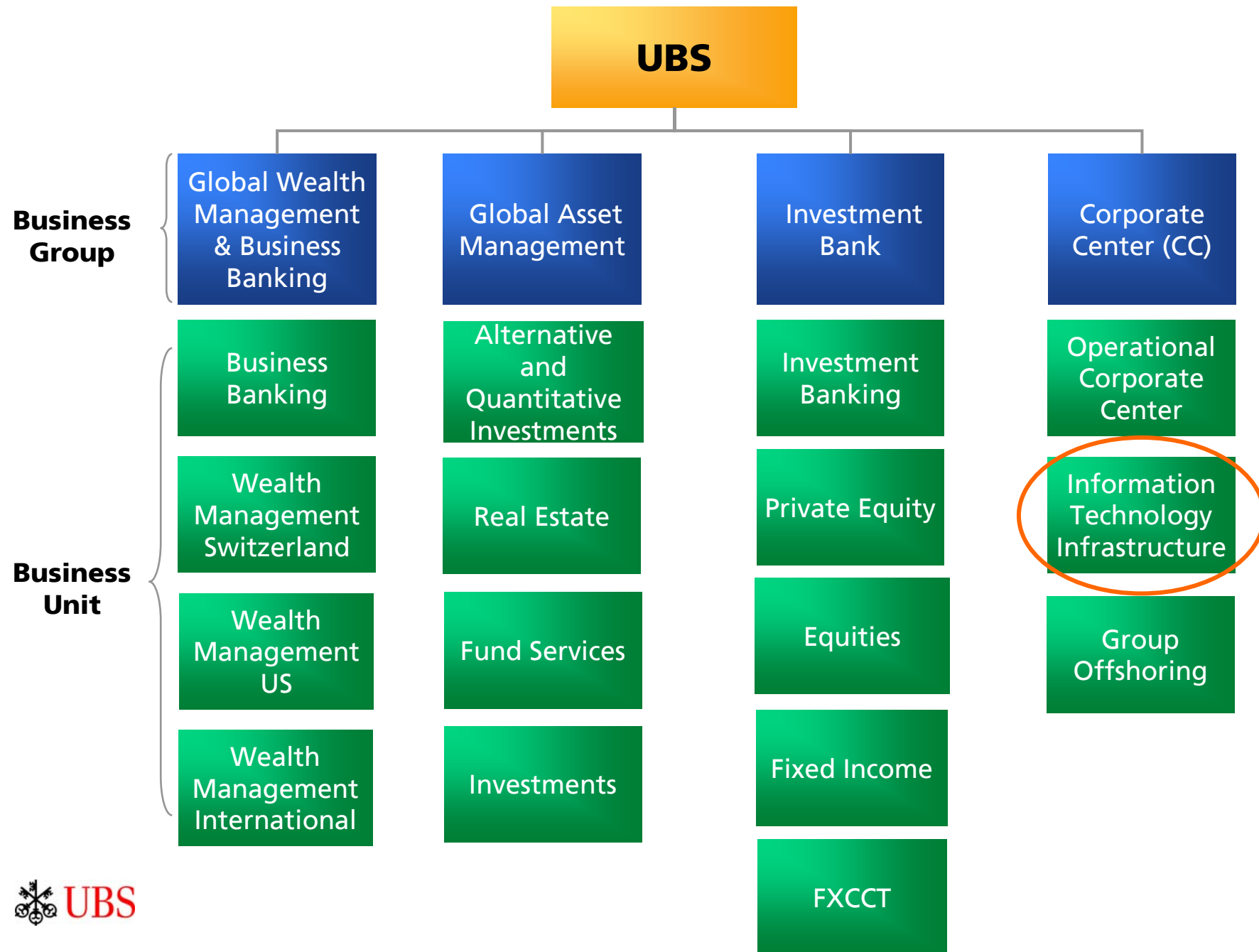

UBS IT Landscape

Business	IB	Global WM&BB		Global AM
		WMUS	CH & International	
Development	IT	ISD	IT	IT
Infrastructure	IT Infrastructure (ITI)			

ITI Global Presence (outside of CH)



	Headcount (full-time equivalents)	Locations	Countries
Switzerland	1'617	16	
EMEA	580	4	3
Americas	1'243	14	3
APAC	705	6	5
World wide	4'145	40	12

Mainframe Architecture & Engineering ...some facts and figures

Some Mainframe Statistics

It has been reported that:

- ◆ 90% of Fortune 1000 companies use mainframes for their mission critical applications
- ◆ Over 70 % of corporate data resides on or originates from mainframes
- ◆ The quality of service offered by mainframes means they are the preferred technology for many business critical applications
 - Finance
 - Databases
 - Credit card clearance
 - Defense
 - Many more.....

Anybody Interested into New Workload?

- ◆ More than 60% of IBM mainframe revenue is now driven by new workloads
 - Approximately 20% of revenue and 30% of MIPS are coming from Linux customers
- ◆ Linux ISV software for System z increased 100% in 2006
 - This results in a total of nearly 1000 certified applications such as Oracle 10g or SAP
- ◆ Customers are running zLinux increased 30% year-to-year
- ◆ The Swiss System z hardware revenue grew over 50%
 - And this at shrinking hard- and software prices

Current Swiss Mainframe Landscape

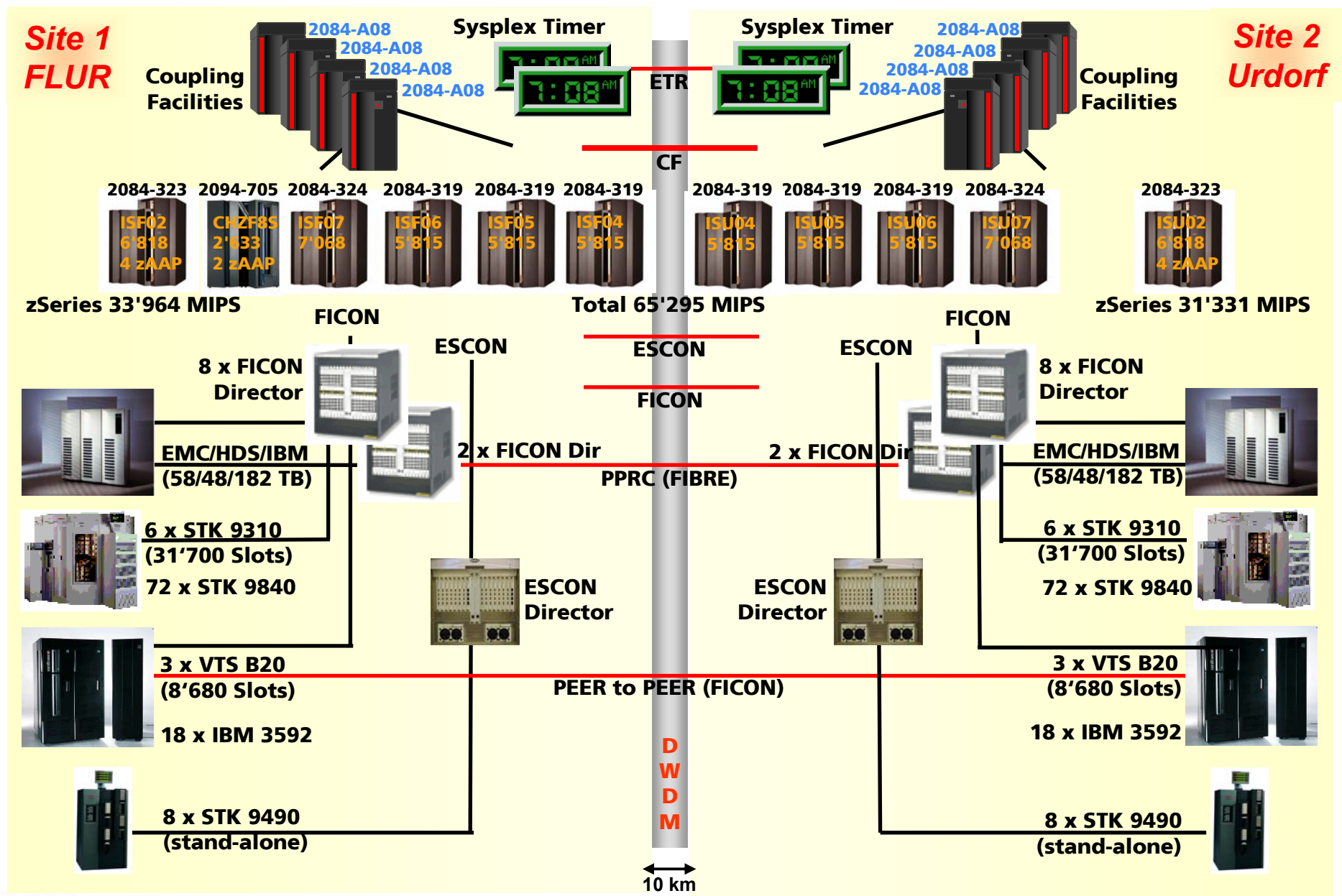

Platform Distribution Process @ UBS

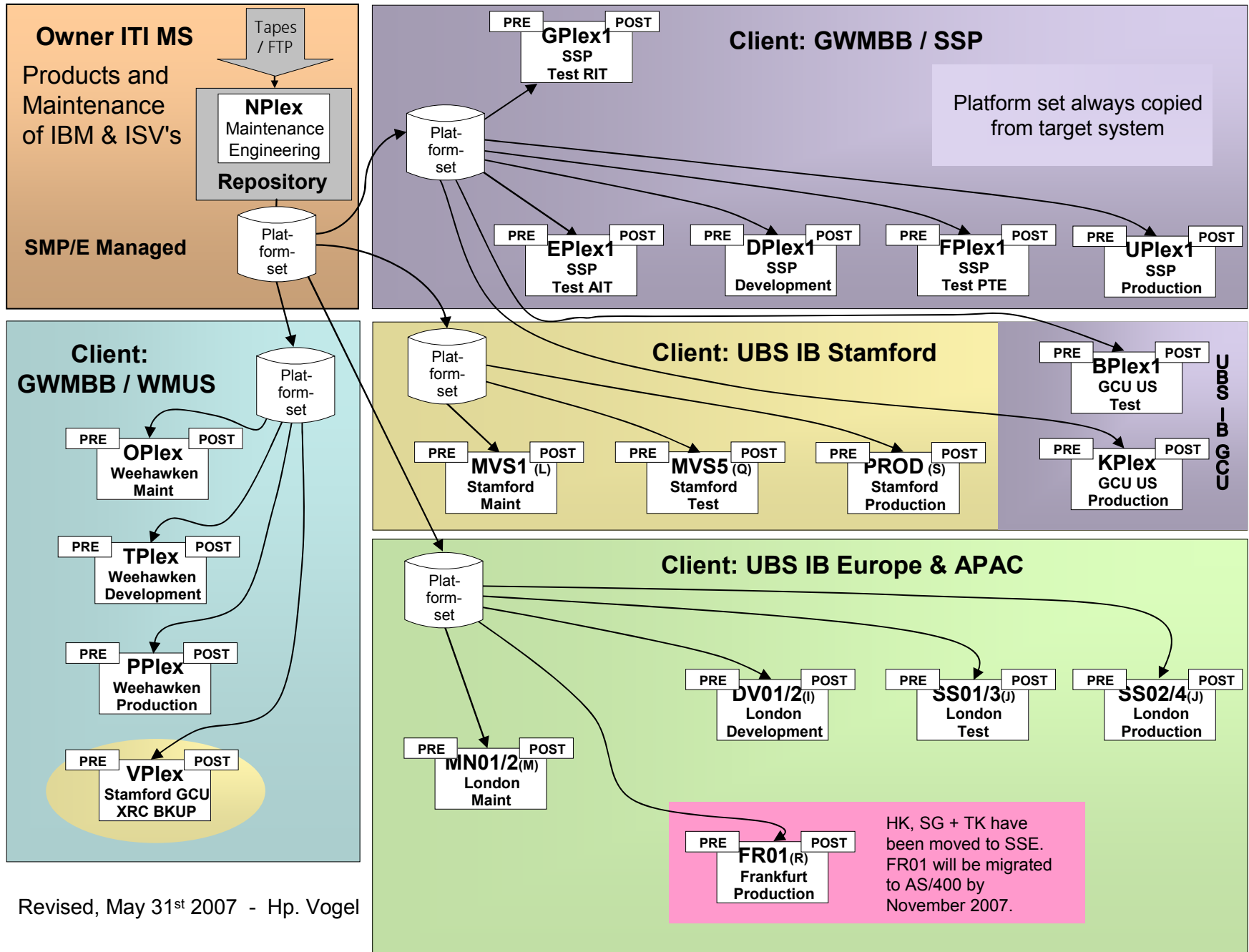

Detailed layout of Campus' in CH & USA

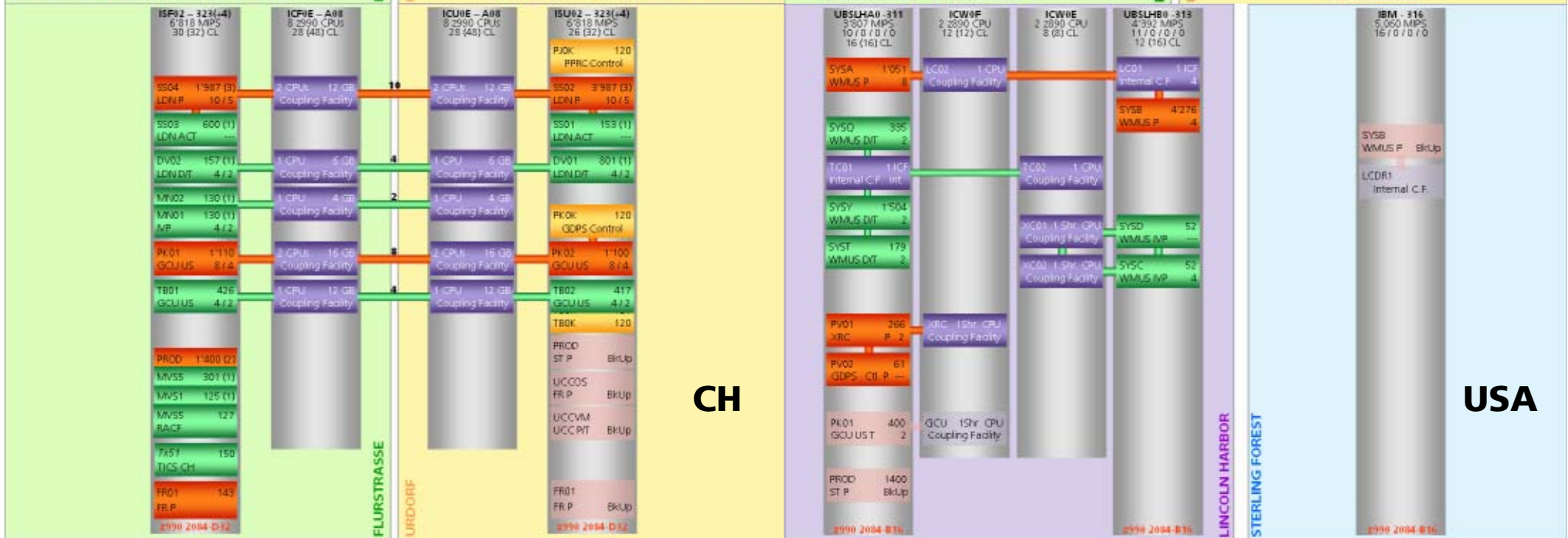
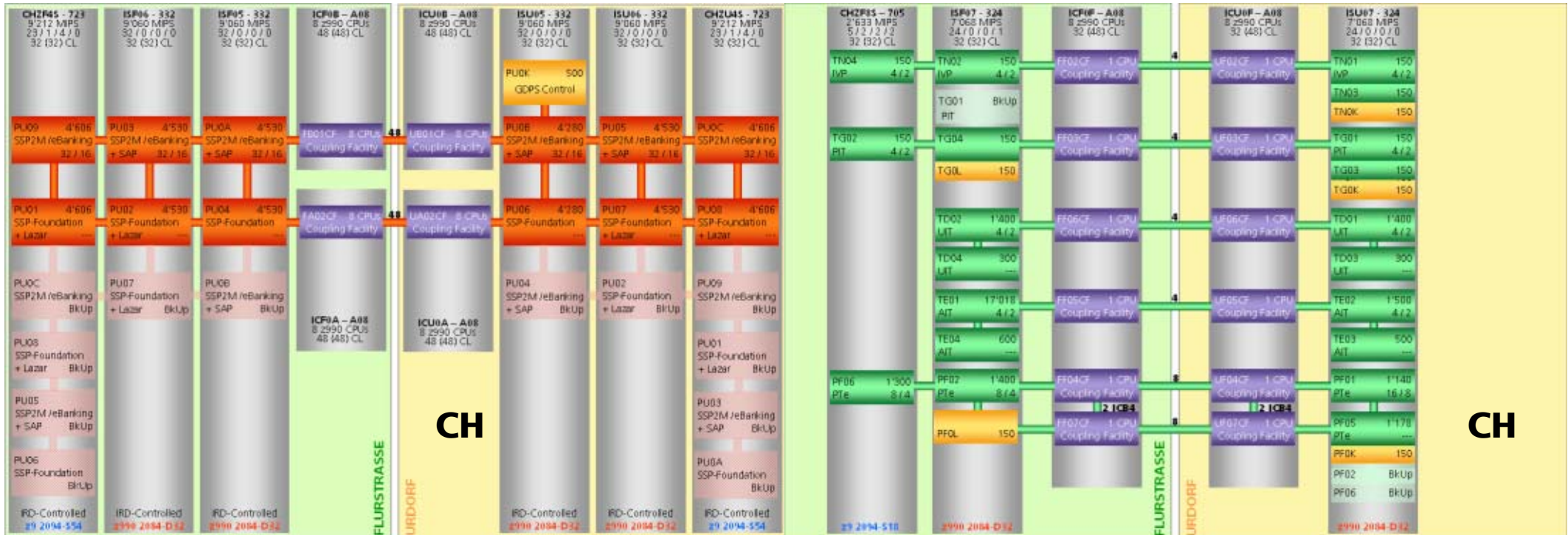

zSeries DASD Storage Overview

← US DASD – ~100 TB mirrored

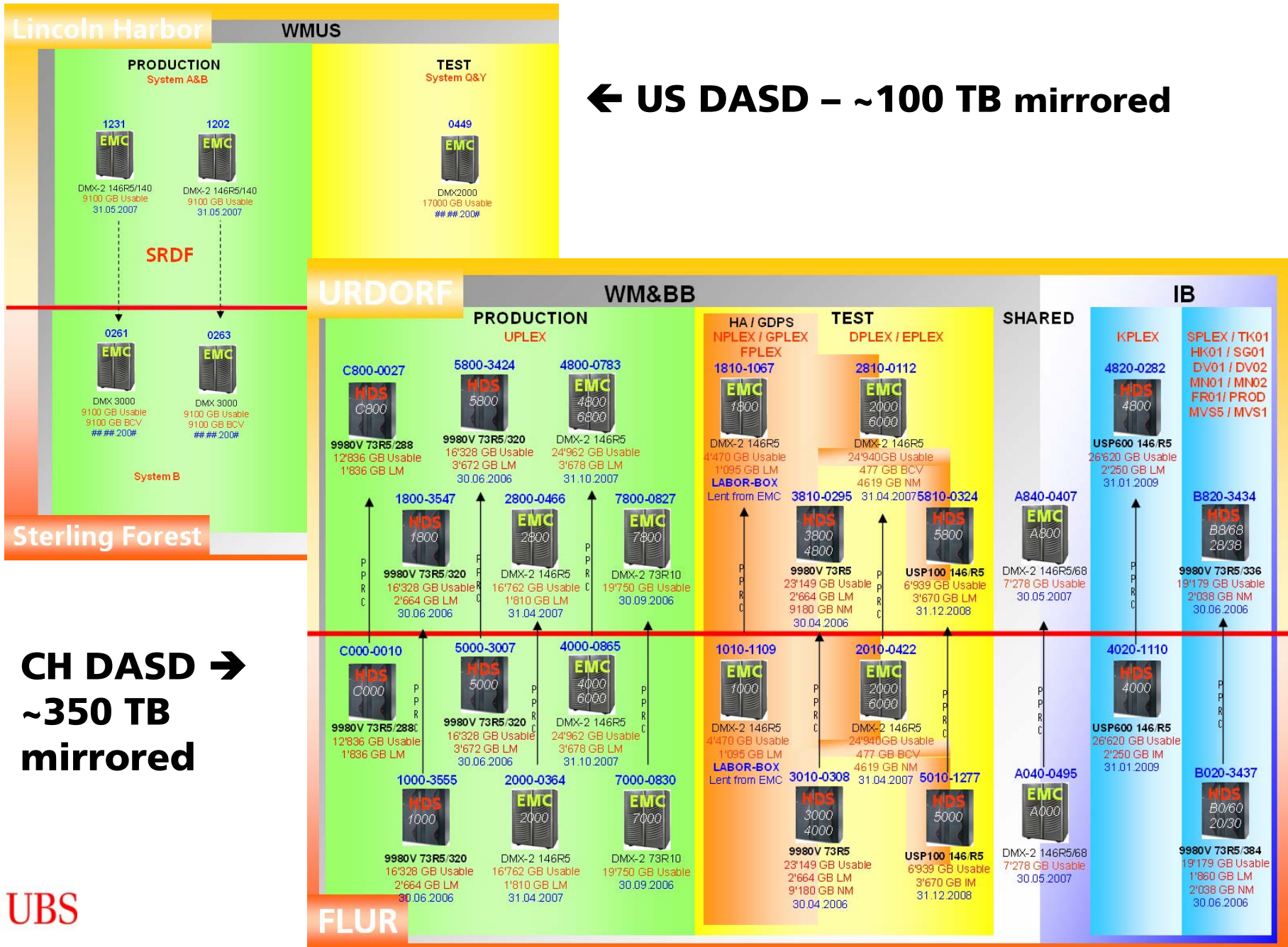

CH DASD →
~350 TB mirrored

Global CICS Environment's

SSP and IB

- ◆ 13 CICSplexes (9 SSP, 3 SSE, 1 ASIA)
- ◆ 51 CMAS' (CICS Managing Address Space - connection to CPSM)
- ◆ ~983 CICS Regions

WMUS

- ◆ 4 CICSplexes
- ◆ 6 CMAS' (CICS Managing Address Space - connection to CPSM)
- ◆ 194 CICS Regions

Overview CICS Definitions and TRX figures

Total Transactions per day and per business group:

UBS CH / WM&BB:

UPLEX: 21'000'000
FPLEX: 1'500'000
EPLEX: 700'000
DPLEX: 800'000
GPLEX: 50'000
NPLEX: 40'000
BPLEX: 100'000

WMBB-Total: ~ 25 mio TRX

UBS WMUS:

PPLEX: 16'500'000
TPLEX: 720'000
OPLEX: Not available (Maintenance)

WMUS-Total: ~ 17 mio TRX

UBS IB:

FR01: 14'000
HK01: 33'000
SG01: 55'000
TK01: 40'000
SPLEX: 3'800'000
YPLEX: 180'000
MVS5: 150'000
PROD: 1'000'000

IB-Total: ~ 6 mio TRX

DB2, MQ & SAP Environments

SSP and IB

- ◆ 111 DB2 members and 33 data sharing groups
 - Largest data sharing group has 12 members (UD)
 - 35 TB DB2 data overall
 - ~300'000 Batch Jobs per night
 - ~30'000 Users in production
- ◆ Working with DB2v8.1
- ◆ MQv5.3 is used in production
- ◆ SAP Kernel v6.4.0 is used in production
The data server (DS) and the application server (AS) are still residing on z/OS (however it is the clear plan to move all of the AS load to the Sun Solaris Ux boxes. Only the ENQ server & DS will remain on z/OS)

Total Anzahl von Jobs ausgeführt in der Produktion

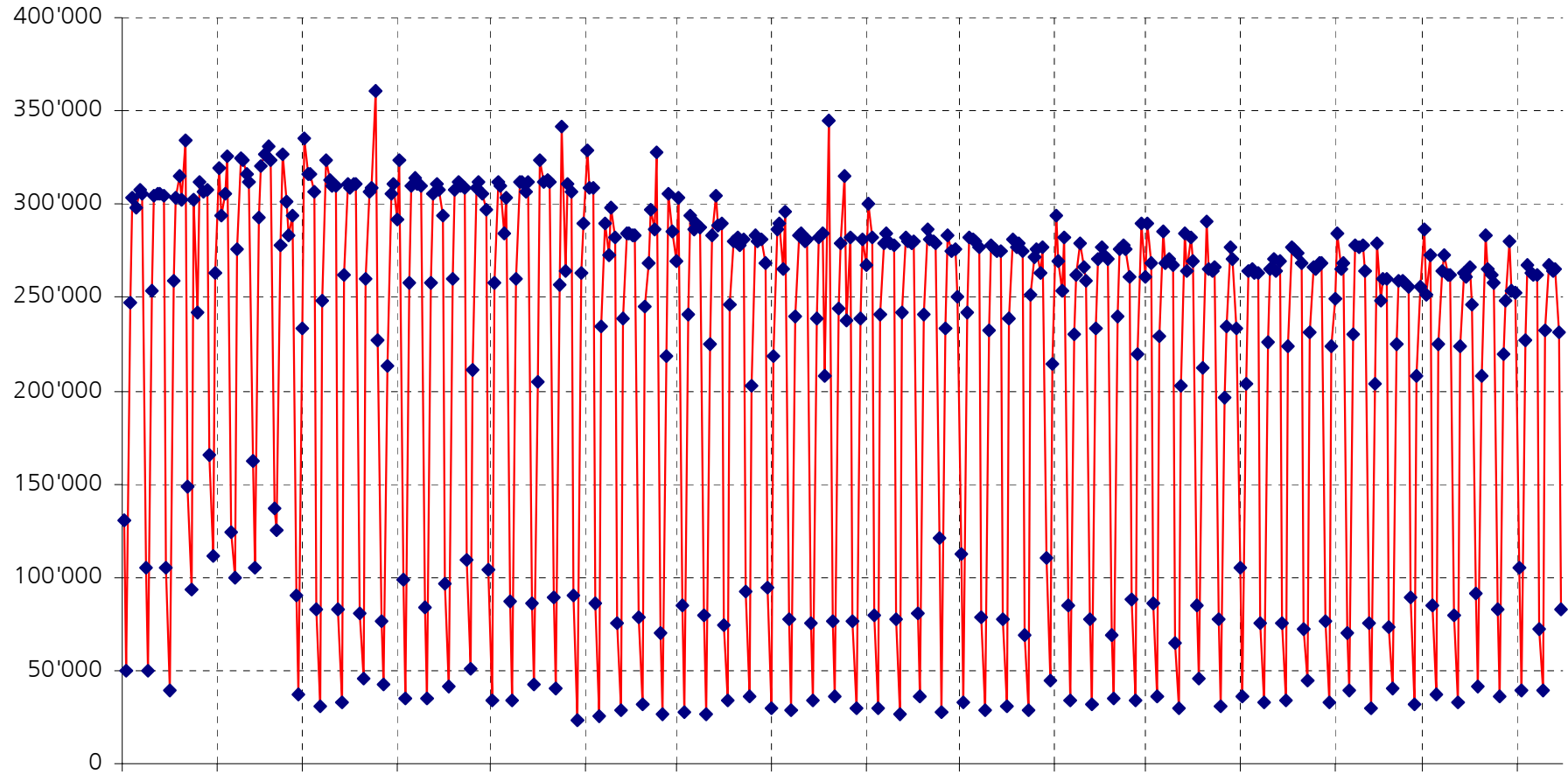

UBS als Arbeitgeber



Mainframe Engineering & Architecture - Age Pyramid

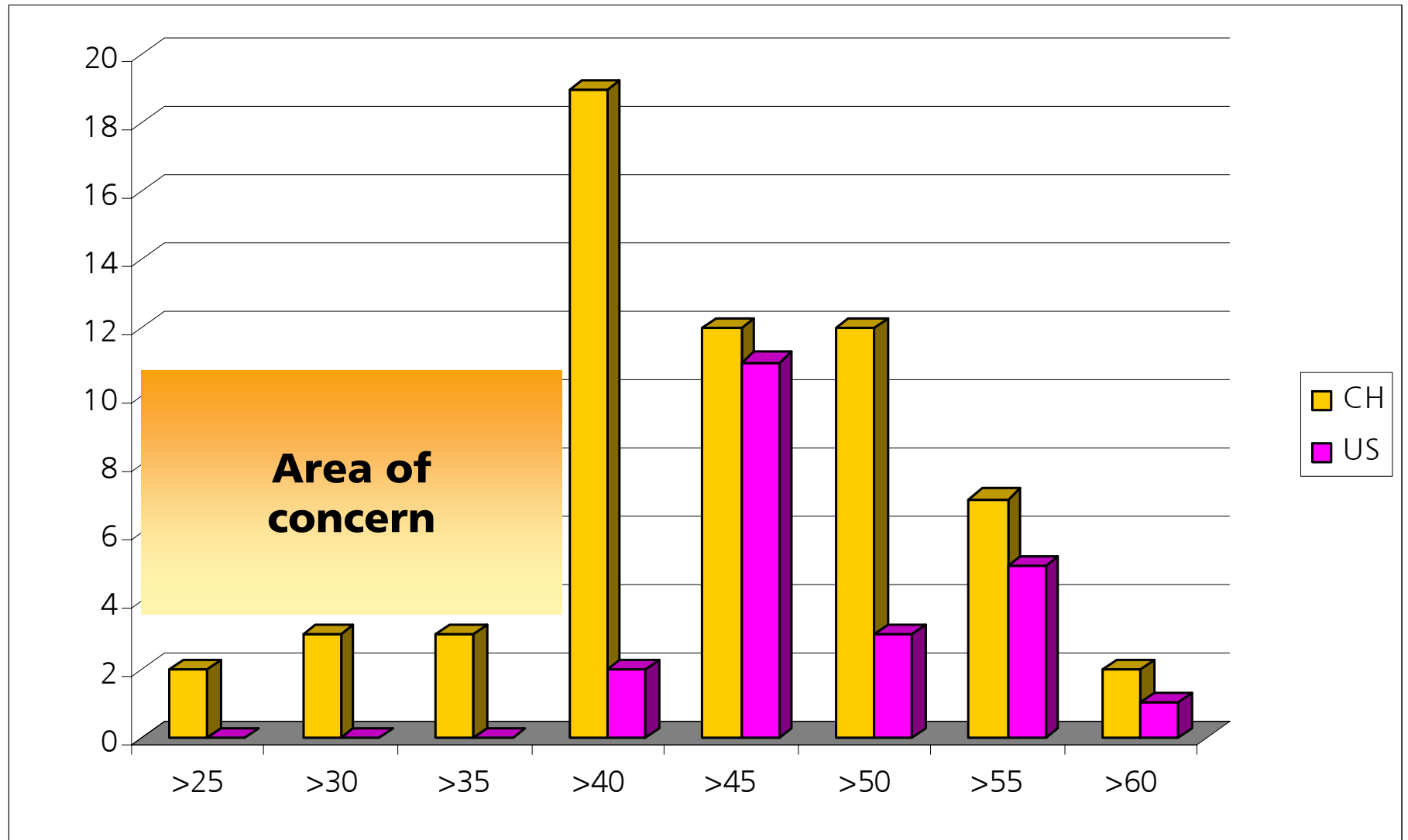

Goal for Trainees and UBS

◆ Goals Trainees:

- All Trainees have completed the “IBM zSummer University” (Berlin/Bochum etc.)
- Trainee program required to receive diploma of University
- Duration of Trainee program approximately six months each
- Become familiar with different areas of IBM Mainframe Software Engineering
- Decide on permanent job opportunity after Trainee program completion
- **Strong networking between zNextGen**

◆ Goals UBS:

- See how Trainee’s perform in a work environment
- Possibility of hiring after Trainee program if Trainee and UBS “like” each other

◆ Welcome Day to introduce UBS as a Bank to Trainees / New Employees

Trainee Programm 2007

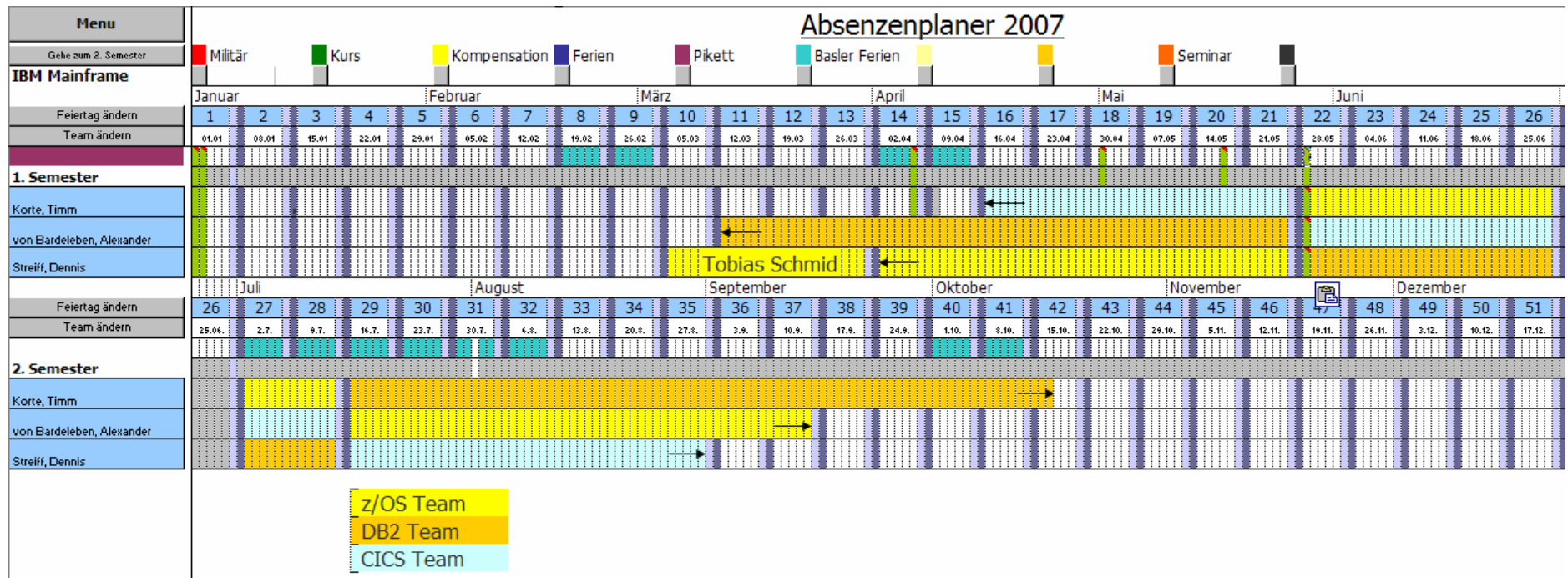

- ◆ Im momentanen „Trainee Programm“ befinden sich 3 Trainees welche nach je ca. 2 Monaten in den drei Teams rotieren
- ◆ Jeder Trainee erhält spezifische Aufgaben mit einem reellen Hintergrund
 - z.B. Entwicklung einer Health-Checker Funktionalität die danach produktiv im Einsatz bleibt
 - Entwicklung eines DB2 DSNZPARM Parameter Vergleich Programms via IntraWeb
- ◆ Arbeitsplatz ist Basel (Nähe zu Deutschland gegeben...)

UBS als Arbeitgeber

Stage - Wissenstransfer on-the-job innert relativ kurzer Zeit

Angebot: Stage/Praktikum in der Schweiz

- ◆ Arbeitsvertrag über 3 – 6 Monate
- ◆ Finanzieller Ausgleich (Monatslohn)
- ◆ Arbeitsort: Basel
- ◆ persönliche Betreuung ("Götti" resp. Pate) pro Team

UBS als Arbeitgeber

Einsatz in den Bereichen:

- ◆ z/OS
- ◆ CICS
- ◆ DB2
- ◆ andere Bereiche möglich

UBS als Arbeitgeber

- ◆ Eine Aufenthaltsbewilligung benötigt eine Vorlaufzeit von bis zu 2 Monaten
- ◆ Es braucht einen Qualifikationsnachweis in den Bewerbungsunterlagen (zB. Studiennachweis) (sehr wichtig)
- ◆ Der monatliche Lohn wird altersabhängig festgelegt
- ◆ Die Praktikumsphase wird als normaler Angestellter verbracht
- ◆ Schweizerische Steuer entsprechend zwischen 13% und 15% (alles in allem Steuer, AHV, Pensionskasse, ALV kann mit +/- 20% Abzug gerechnet werden)
- ◆ Ab einer Beschäftigungsdauer von mehr als 2 Monaten und einem Verdienst von mehr als 19'000 CHF / Jahr wird Pensionskassenbeitrag fällig (Beitrag bis 24 Jahre = 1%, ab 25 Jahre = 7 %)
- ◆ Pensionskassenbeitrag wird nach Beendigung des Arbeitsverhältnisses zurückerstattet (auf Sperrkonto !?)

UBS als Arbeitgeber

Join a global leader

We are pledged to the highest standards of corporate conduct

<http://www.ubs.com/careers>

UBS als Arbeitgeber

Kontakt

UBS AG

Hanspeter Vogel
Gartenstrasse 9, P.O. Box

CH-4052 Basel
Switzerland

+41 61 288 42 00

hanspeter.vogel@ubs.com